

SUZUKI DL 1000 V-Strom Motorschutz Montagehinweise

Alle vom Motorrad gelösten Schrauben sind gemäß Herstellerangaben wieder zu montieren, oder mit von SW-MOTECH gelieferten Schrauben zu ersetzen. Falls nicht anderweitig definiert, diese Schrauben nach Tabelle anziehen.

M6	9,6 Nm
M8	23 Nm
M10	46 Nm

Gegebenenfalls Schrauben mit flüssiger Schraubensicherung einkleben.

Prüfen Sie nach 50 km alle Verbindungen auf festen Sitz.

SW-MOTECH GmbH & Co. KG
Bahnhofstrasse 44d
35282 Rauschenberg
-Germany-

Tel.: ++ 49 (0) 6425 816 800
Fax: ++ 49 (0) 6425 816 810

www.sw-motech.com

Skid plate Mounting Instructions

SW-MOTECH products should be installed by a qualified, experienced motorcycle technician. If you are unsure of your ability to properly install a product, please have the product installed by your local motorcycle dealer. SW-MOTECH takes no responsibility for damages caused by improper installation.

All screws, bolts and nuts, including all replacement hardware provided by SW-MOTECH, should be tightened to the torque specified in the OEM maintenance manual for your motorcycle. If no torque specifications are provided in the OEM maintenance manual, the following torques may be used:

M6	9,6 Nm
M8	23 Nm
M10	46 Nm

All screws, bolts and nuts should be checked after driving the first 50 km to ensure that all are tightened to the proper torque.

Medium strength liquid thread-locker (i.e., "Loctite") should be used to secure all screws, bolts and nuts.

! Justage des Motorschutzes über die Langlöcher in Fahrtrichtung. Nur so kann ausreichender Abstand zwischen Motorschutz und Auspuff gewährleistet werden.

Adjust the skid plate with the ablons holes (in driving direction) to have enough space between the exhaust and skid plate.

! Achtung:
Die Kurven- und Bodenfreiheit kann durch einen Motorschutz eingeschränkt werden.

Attention:
Cornering and ground clearance can be reduced by using a skid plate.

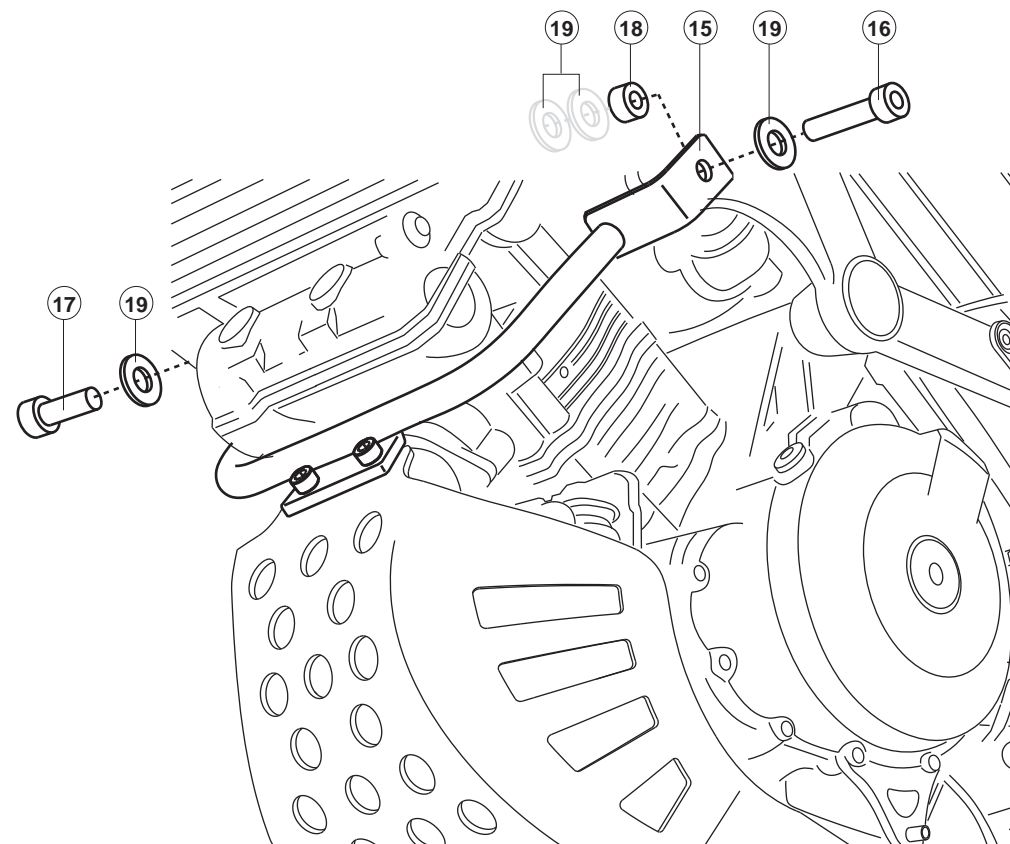

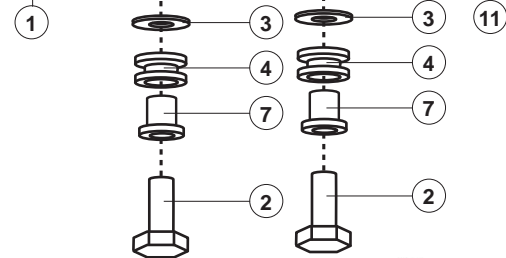
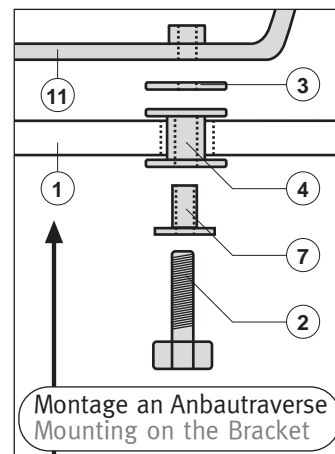
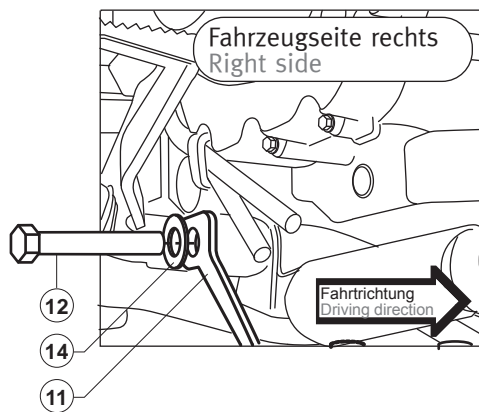
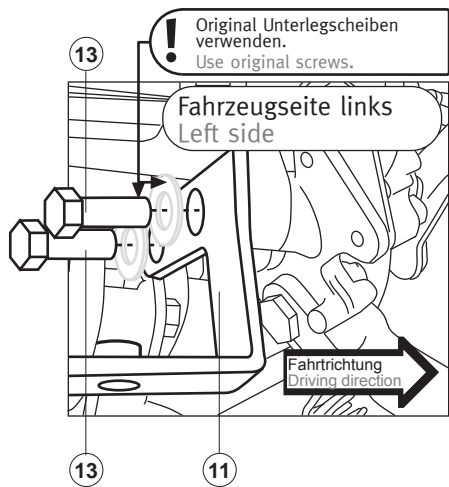
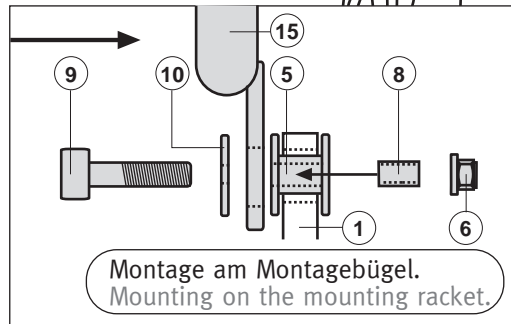
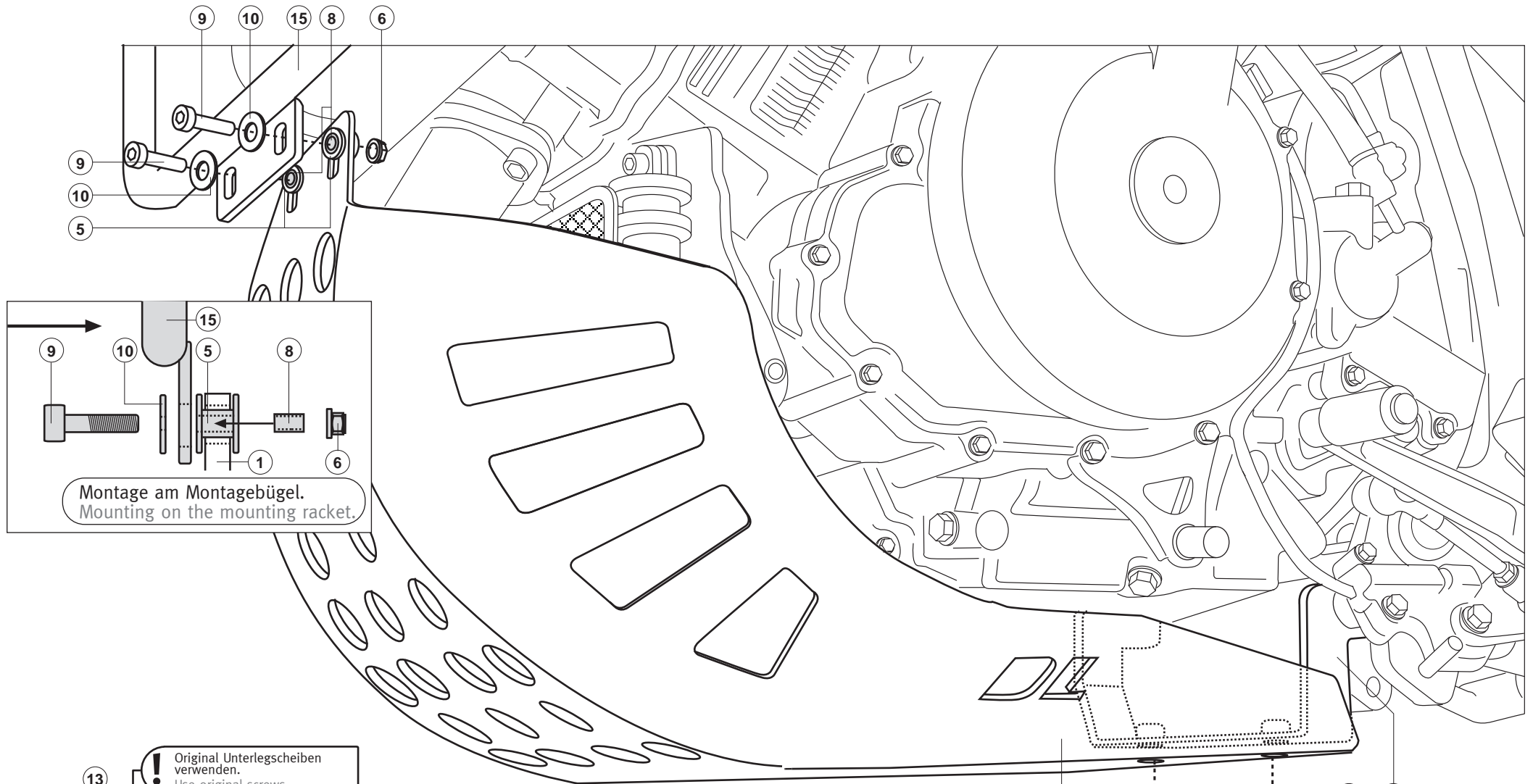

1 Motorschutz
Skid Plate



MSS.05.265.900

Anzahl/ Pcs. 1

4 Gummitülle
Rubber Element



GT.00.12H3488

Anzahl/ Pcs. 2

7 Distanzbuchsen mit
Bund
T-Bushing

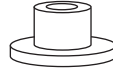

MSS.05.296.006

Anzahl/ Pcs. 2

11 Anbautraverse
Bracket

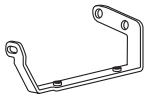

MSS.05.265.005 00

Anzahl/ Pcs. 1

15 Montagebügel
Mounting Racket

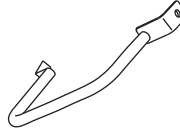

MSS.05.265.910 01

Anzahl/ Pcs. 1

19 Unterlegscheibe
Washer



A 10,5 DIN 125

Anzahl/ Pcs. 6

2 Sechskantschraube
Hexagon Screw

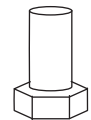

M8 x 20 DIN 933

Anzahl/ Pcs. 2

5 Gummitülle
Rubber Element



GT.00.12H3472

Anzahl/ Pcs. 2

8 Distanzbuchsen
Spacer



Da:8 Di:6,4 h:7

Anzahl/ Pcs. 2

12 Sechskantschraube
Hexagon Screw

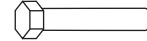

M8 x 50 DIN 931

Anzahl/ Pcs. 1

16 Zylinderschraube
mit Innensechskant
Hexagon Socket
Screw



M10x1,25x100 DIN 912

Anzahl/ Pcs. 1

3 Unterlegscheibe
Washer



A 8,4 DIN 9021

Anzahl/ Pcs. 2

6 Mutter mit Bund
Lock Nut



M6 DIN 6927/b

Anzahl/ Pcs. 2

9 Zylinderschraube
mit Innensechskant
Hexagon Socket
Screw



M6 x 20 DIN 912

Anzahl/ Pcs. 2

13 Sechskantschraube
Hexagon Screw

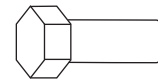

M12 x 1,25 x 35 DIN 960

Anzahl/ Pcs. 2

17 Zylinderschraube
mit Innensechskant
Hexagon Socket
Screw

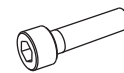

M10x1,25x80 DIN 912

Anzahl/ Pcs. 1

10 Unterlegscheibe
Washer



A 6,4 DIN 9021

Anzahl/ Pcs. 2

14 Unterlegscheibe
Washer



A 8,4 DIN 9021

Anzahl/ Pcs. 1

18 Distanzbuchse
Spacer



Da:20 Di:10,5 h:8

Anzahl/ Pcs. 2